

THIS WATER CAME FROM MANURE

Lisa Fast

Marketing
& Communications
Manager



Euroopa Maaelu Arengu
Põllumajandusfond:
Euroopa investeeringud
maapiirkondadesse



LIVESTOCK
WATER
RECYCLING

We Are Changing the Value of Waste

What we do:

Our on-farm approach to manure treatment achieves triple bottom line outcomes:

1. Meeting the growing demand for food
2. Increasing farmer profitability
3. Protecting the environment and public health.



We digitize the footprint of manure to provide actionable data insights to create value and improve food security. By facilitating access into digital marketplaces for fertilizer and renewable natural gas (RNG) as well as potential for nutrient trading, greenhouse gas and carbon credits, a waste-to-worth value proposition is enabled.





LIVESTOCK
WATER
RECYCLING

Proven Patented Technology

LWR's patented process technology uses mechanical and chemical treatment for the removal of biosolids from liquid streams. LWR technologies are focused on the concentration of organics, phosphorous, potassium, and nitrogen from manure. As the liquid flows through this process, solids are sequentially removed from the influent stream creating valuable crop fertilizers and clean water.

The platform consists of bulk solids removal, fine solids removal, and membrane recovery.

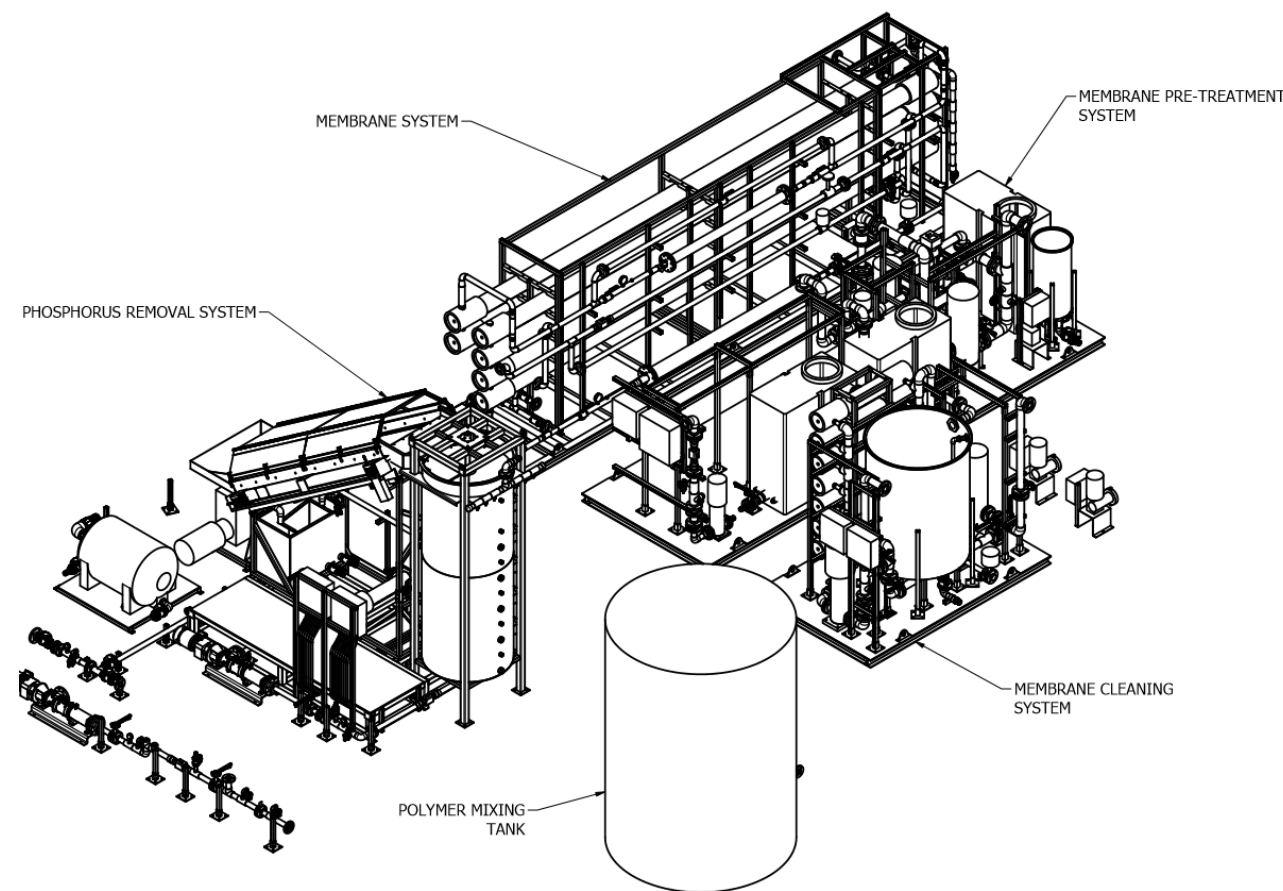



LIVESTOCK
WATER
RECYCLING

FIRST WAVE



Proven Patented Technology

The systems are manufactured in Calgary and sold as 5 STANDARD MODELS depending on the farm sizes:

SYSTEM FLOW RANGE (m³/year)

SPROUT	4353 - 9842
PLANT 10:	21766 - 72944
PLANT 40:	59241 - 145738
PLANT 85:	90850 - 209711
PLANT 185:	181700 - 401253





LIVESTOCK
WATER
RECYCLING

System Outputs

The award winning LWR treatment process considers the unique composition of manure liquids and is designed to treat manure in an environmentally safe way that allows for segregation, concentration and re-use of nutrients. This world leading technology creates the following outputs:

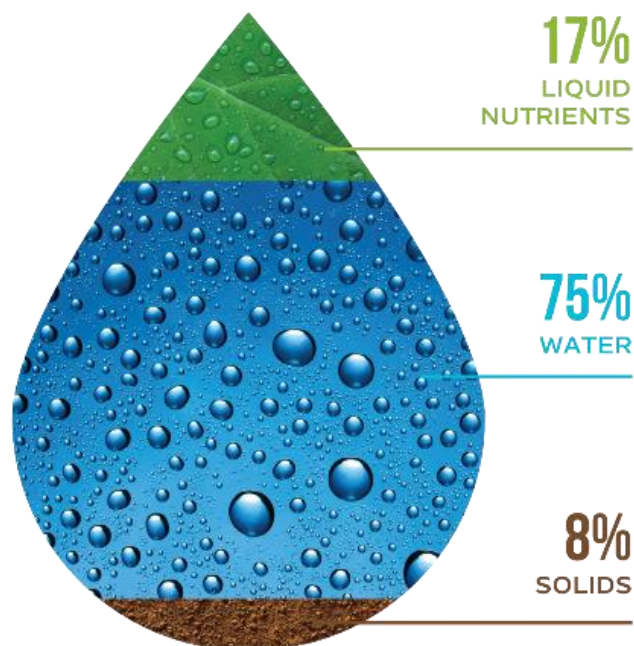

Nutrient Solids: Dry and rich in phosphorus, solids can be strategically land-applied to crops as fertilizer to increase crop production. The solids also contain trace amounts of potassium and nitrogen.

Liquid Nutrient Concentrate: Containing ammonium sulphate and potash, the liquid concentrate is fifteen to thirty percent (15–30%) of the total liquid volume and can be strategically land applied as crop fertilizer. It is stabilized for easy transport to neighboring farms.

Water: A completely nutrient free effluent; Up to 75% of the liquid volume is transformed into clean, potable water. This is the only technology in the world that can produce water that can be reused for crop irrigation, cleaning or watering of livestock at these economics.





LIVESTOCK
WATER
RECYCLING

System Outputs

Solids are typically between 25-28% dry weight and can be stacked up to 10 feet high.

Move solids economically for fertilization or sell off farm.

For a very low capital cost, a drier can be added for the most economical transportation of solids.





LIVESTOCK
WATER
RECYCLING

System Outputs

Liquids used for flushing, cleaning fiber separator, and cleaning sand lane

Applied by dragline or pivot irrigation based on agronomic application rates





LIVESTOCK
WATER
RECYCLING

A Digital Farming Revolution

LWR's first of its kind data analytics package digitizes the manure footprint of each operation through on-system sensors. This provides actionable data insights that create value for the livestock producers. These insights can inform about flow rates, productivity, nutrient content, herd health, as well as facilitating access to digital markets for fertilizer, nutrient trading, greenhouse gas and carbon credits.





LIVESTOCK
WATER
RECYCLING

A Digital Farming Revolution

myPLAN Mobile Application

Custom Analytics Reporting indicates:

- Suspended Solids
- Volatile Solids
- Total treatment volume
- Clean water recovery
- Nutrient recovery
- Reports from HUB and SPOKE farms
- Customized reports per site

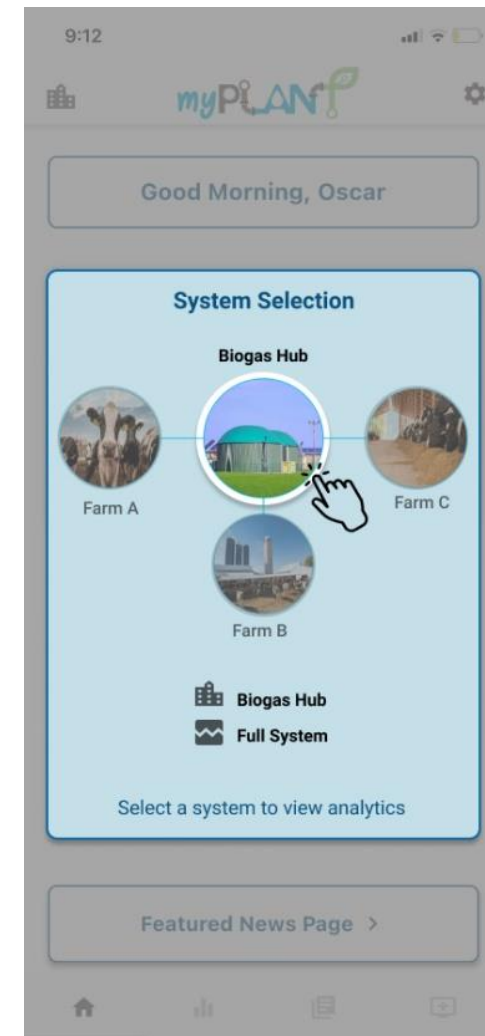
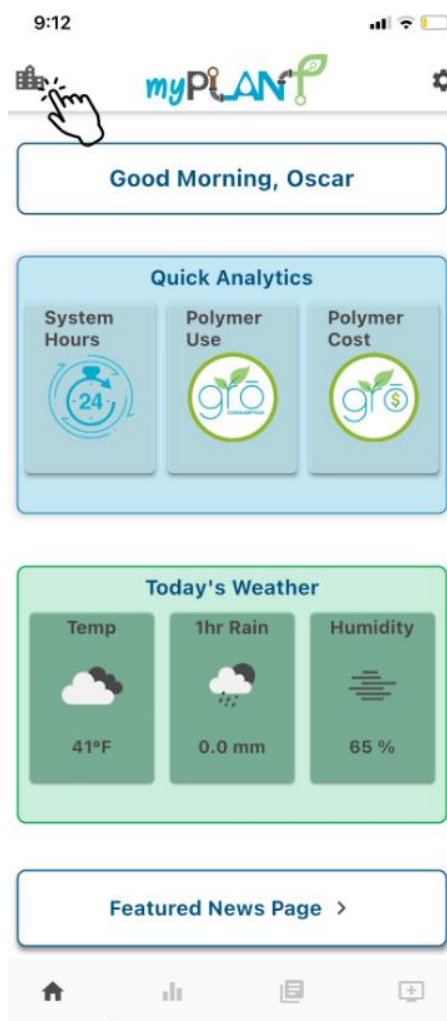

ON-FARM VALUE PROPOSITION

INCREASED:

Water Recycling
Farm Revenue
Fertilizer sales
Crop yields
Herd size
Soil regeneration



REDUCED:

Odors
Health problems
GHG emissions
Nutrient losses
Manure hauling costs



LIVESTOCK
WATER
RECYCLING

Case Study: Dairy, Wisconsin

RESULTS:

1. Corn yields ↑ 3-5 tons/acre
2. Haylage yields ↑ 1 ton/acre
3. Increased herd size
4. Reduced manure expenses
5. Reduced SCC by 30%

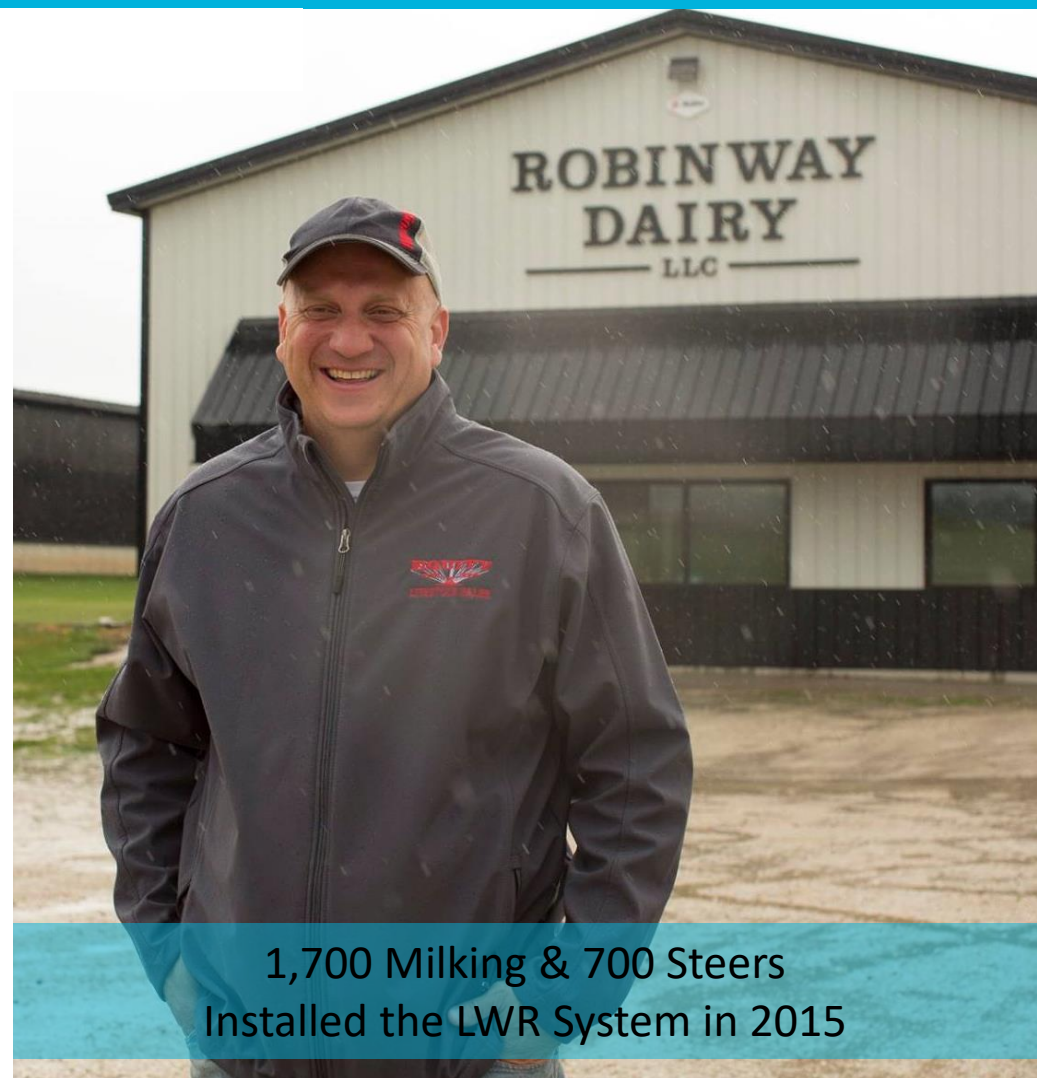

1,700 Milking & 700 Steers
Installed the LWR System in 2015







900 Milking cows

The First Wave System was an integral part of their millennial succession plan



Installed the FIRST WAVE
in 2017





- 2,400 Milking Cows | 1,000 Steers
- Farming 3,500 acres

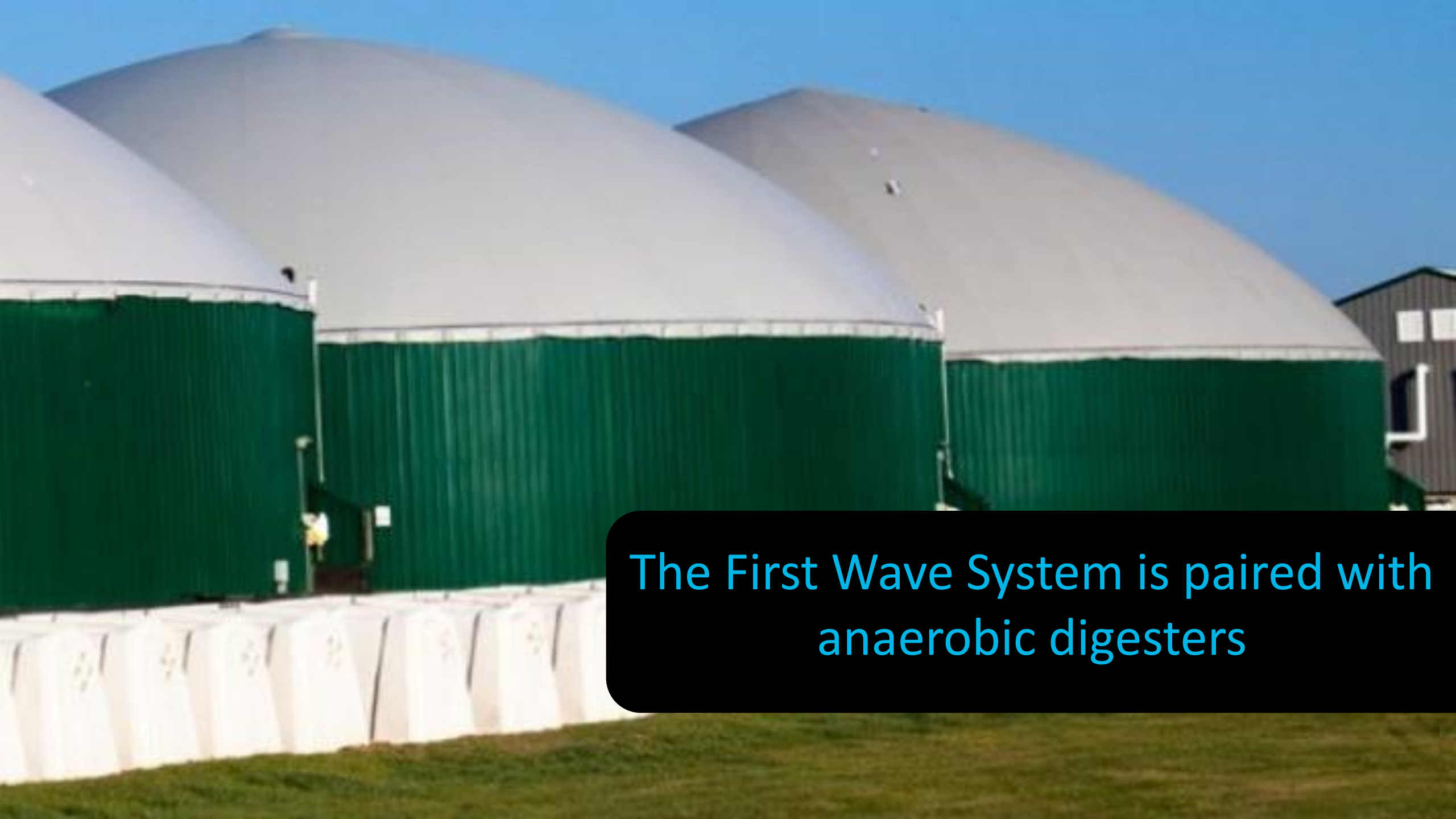

The First Wave System is paired with anaerobic digesters



**LIVESTOCK
WATER
RECYCLING**

Case Study: Lebanese Dairy Farm

- Installed LWR System in 2019
- Large irrigation project with pivots and integrated irrigation systems
- Drastically improved feed crop production
- Healthier, happier cows
- Alleviated pressure on the Litani River





**RENEWABLE
NATURAL GAS**
with **LIVESTOCK WATER RECYCLING**



LIVESTOCK
WATER
RECYCLING

Technology Integration with the Renewable Natural Gas Market

LWR concentrates 85% of the manure's Volatile Solids resulting in increased gas production.

The solids fraction can be economically trucked to a central digester HUB. The systems can also treat digestate for full nutrient control and clean water recovery.

Scenario 1:

Treat manure liquids on a single farm prior to feeding solids into a digester.

Scenario 2:

Treat liquids on multiple farms then haul solids economically to central hub digester.

Scenario 3:

Treat digestate post gas production.

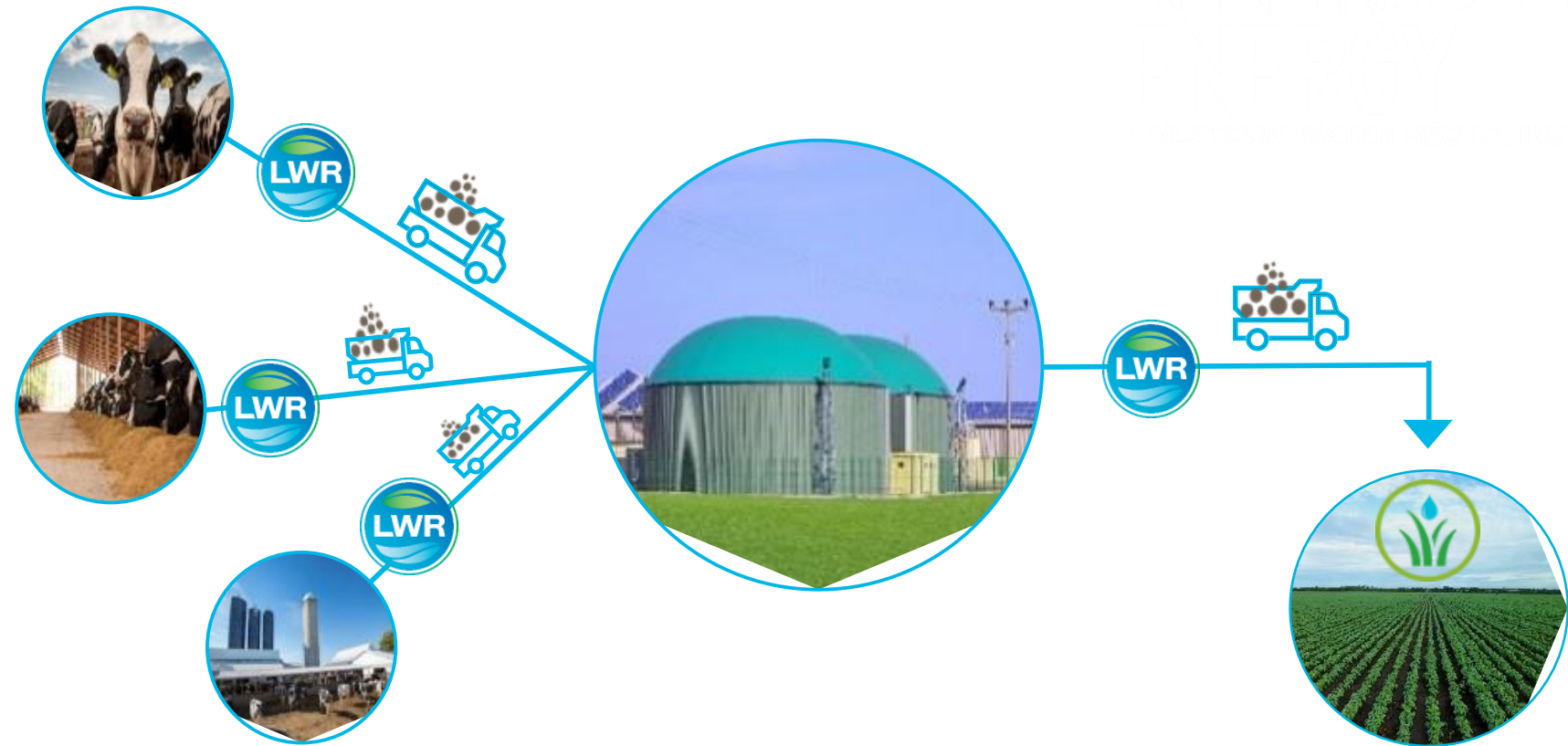



LIVESTOCK
WATER
RECYCLING

The Global Leader in Nutrient Recovery



System installations
Sales in progress



- 20+ systems installed
- Systems sold across 11 American States and expanding
- System installed on the largest dairy farm in Lebanon
- Global interest increasing exponentially



Dairy Farmers of America







LIVESTOCK
WATER
RECYCLING



SUSTAINABLE DEVELOPMENT GOALS

LWR fertilizer PLANTS operating in the market already have the potential to treat over **one billion gallons** of manure annually, and can recover over **half a billion gallons** of clean, reusable water: the equivalent consumption of 15,000 Americans!

Our goal is to transform **one trillion gallons** of manure and food waste bioliquids into recycled clean water by 2050, directly impacting 10 of the UN's Sustainable Development goals.





Data driven, sustainable, responsible and resource-efficient milk production is important to the future of our planet



LIVESTOCK
WATER
RECYCLING

Thank you

For more information:

Lisa Fast, Marketing and Communications Manager

403.203.4972

lisa.fast@livestockwaterrecycling.com